

Features

- 4:1 Wide Input Range
- Operating Temperature Range: -40~105°C
- Approved to cURus, UKCA, CE, RoHS & REACH
- Approved to IEC/UL/EN62368-1 & EN50155
- Efficiency up to 92%
- EMC Class A & B
- Single & Dual 40W Output Models
- OCP, OTP, OVP, SCP & UVP
- Available with optional heatsink (HS)

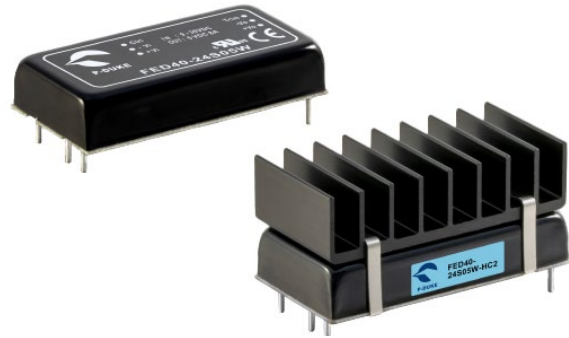

Ideal Power's 43FED40xyzW 40W Series DIP DC/DC Converters are certified to cURus, UKCA, CE, RoHS, REACH & IEC/UL/EN 62368-1, EN 50155 Standards and comply with the relevant Efficiency Regulations. These are primarily used in ITE, Video & Audio, Railway Industries and customised solutions are available upon request.

Part Number Structure

43FED40	-	48	S	05	W	-	M3	N	HC
Series Name		Output Power (VDC)	Output Quantity	Output Voltage (VDC)	Input Range		Operating Temp Options	Remote Control Options	Assembly Options
		24: 3 ~ 36 48: 18 ~ 75 110: 43 ~ 160	S: Single D: Dual	3P3: 3.3 05: 5 12: 12 15: 15 24: 24 12: ±12 15: ±15 24: ±24	4 : 1		□: Standard -40~+105°C With derating N: M3 Version -55~+105°C With derating	□: Positive Logic N: Negative Logic	□: None HC: 7G-0020C-F; H=0.22" (※NRND) HC1: 7GA0120P01-F; H=0.3" HC2: 7GA0121P01-F; H=0.5" HC3: 7GA0122P01-F; H=0.8" ※NRND: Not recommended for new designs

Models

Model Number	Input	Output	Output Current	Input Current	Efficiency	Maximum
43FED40-24S3P3W	9 ~ 36	3.3	10000	15	90	26600
43FED40-24S05W	9 ~ 36	5	8000	15	91	20000
43FED40-24S12W	9 ~ 36	12	3333	15	92	3900
43FED40-24S15W	9 ~ 36	15	2666	15	92	2600
43FED40-24S24W	9 ~ 36	24	1666	15	91	1300
43FED40-24D12W	9 ~ 36	±12	±1666	15	90	± 2600
43FED40-24D15W	9 ~ 36	±15	±1333	15	90	± 1600
43FED40-24D24W	9 ~ 36	±24	±833	15	91	±650
43FED40-48S3P3W	18 ~ 75	3.3	10000	10	90	26600
43FED40-48S05W	18 ~ 75	5	8000	10	92	20000
43FED40-48S12W	18 ~ 75	12	3333	10	92	3900
43FED40-48S15W	18 ~ 75	15	2666	10	92	2600
43FED40-48S24W	18 ~ 75	24	1666	10	91	1300
43FED40-48D12W	18 ~ 75	±12	±1666	10	90	± 2600
43FED40-48D15W	18 ~ 75	±15	±1333	10	90	± 1600
43FED40-48D24W	18 ~ 75	±24	±833	10	91	±650
43FED40-110S3P3W	43 ~ 160	3.3	10000	10	88	26600
43FED40-110S05W	43 ~ 160	5	8000	10	89	20000
43FED40-110S12W	43 ~ 160	12	3333	10	90.5	3900
43FED40-110S15W	43 ~ 160	15	2666	10	91	2600
43FED40-110S24W	43 ~ 160	24	1666	10	90	1300
43FED40-110D12W	43 ~ 160	±12	±1666	10	89	± 2600
43FED40-110D15W	43 ~ 160	±15	±1333	10	89	± 1600
43FED40-110D24W	43 ~ 160	±24	±833	10	91	±650

Input Specifications

Parameter	Conditions	Min	Typ	Max	Unit	
Operating input voltage range	24Vin(nom)	9	24	36	VDC	
	48Vin(nom)	18	48	75		
	110Vin(nom)	43	110	160		
Start-up voltage	24Vin(nom)	--	--	9	VDC	
	48Vin(nom)	--	--	18		
	110Vin(nom)	--	--	43		
Shutdown voltage	24Vin(nom)	7	8	8.8	VDC	
	48Vin(nom)	15.5	16	17.5		
	110Vin(nom)	37	40	42		
Start-up time	Constant resistive load	Power up	--	60	--	ms
		Remote ON/OFF	--	60	--	
Input surge voltage	100 ms, max.	24Vin(nom)	--	--	50	VDC
		48Vin(nom)	--	--	100	
		110Vin(nom)	--	--	170	
Remote ON/OFF	Referred to –Vin pin	Positive logic	DC-DC ON	Open or 3 ~ 12VDC		mA
			(Standard) DC-DC OFF	Short or 0 ~ 1.2VDC		
		Negative Logic	DC-DC ON	Short or 0 ~ 1.2VDC		
			(Option) DC-DC OFF	Open or 3 ~ 12VDC		
		Input current of Ctrl pin	-0.5	0.5		
Remote off input current	3					

Output Specifications

Parameter	Conditions		Min	Typ	Max	Unit
Voltage accuracy			-1.0	--	+1.0	
Line regulation	Low Line to High Line at Full Load		-0.2	--	+0.2	
Load regulation	No Load to Full Load	Single	-0.5	--	+0.5	%
		Dual	-1.0	--	+1.0	
Cross regulation	Asymmetrical load 25%/100% FL	Dual	-5.0	--	+5.0	
Voltage adjustability	Single output	3.3Vout, 5Vout, 12Vout	-10	--	+10	
		15Vout, 24Vout	-10	--	+20	
Ripple and Noise	Measured by 20MHz bandwidth With a 0.1µF/50V X7R MLCC	3.3Vout, 5Vout	--	75	--	mVp-p
		12Vout, 15Vout	--	100	--	
		24Vout	--	150	--	
Temperature coefficient			-0.02	--	+0.02	%/°C
Transient response recovery time	25% Load step change		--	250	--	µs
Over voltage protection	Zener diode clamp	3.3Vout	--	3.9	--	VDC
		5Vout	--	6.2	--	
		12Vout	--	15	--	
		15Vout	--	20	--	
		24Vout	--	30	--	
Overload protection	% Of Iout rated		--	150	--	%
Short circuit protection						Continuous automatic recovery

General Specifications

Parameter	Conditions		Min	Typ	Max	Unit	
Isolation voltage	1 minute	110Vin(nom)	Input to Output	3000	--	--	V DC
			Input (Output) to Case	1600	--	--	
		Others	Input to Output	1600	--	--	
			Input (Output) to Case	1600	--	--	
Isolation resistance	500VDC		1	--	--	GΩ	
Isolation capacitance			--	--	1500	pF	
Switching frequency			225	250	275	kHz	
Safety approvals	IEC/ EN/ UL62368-1					UL:E193009 CB:UL(Demko)	
Standard approvals	EN50155 EN45545-2						
Case material						Copper	
Base material						FR4 PCB	
Potting material						Silicone (UL94 V-0)	
Weight						32g (1.13oz)	
MTBF	MIL-HDBK-217F, Full load					9.073 x 10 ⁵ hrs	

Environmental Specifications

Parameter	Conditions		Min	Typ	Max	Unit
Operating ambient temperature	Standard	With derating	-40	--	+105	°C
	M3 Version	With derating	-55	--	+105	
Maximum case temperature			--	--	105	
Over temperature protection			--	115	--	
Storage temperature range			-55	--	+125	
Thermal impedance	Without Heat-sink		--	10.8	--	
	With Heat-sink	HC	--	10.3	--	
		HC1	--	9.3	--	
		HC2	--	7.7	--	
	HC3	--	6.2	--		
Thermal Shock						MIL-STD-810F
Shock						EN61373, MIL-STD-810F
Vibration						EN61373, MIL-STD-810F
Relative humidity						5% to 95% RH

EMC Specifications

Parameter	Conditions		Level
EMI	EN55032, EN50121-3-2	With external components	Class B
EMS	EN55024, EN50121-3-2		
ESD	EN61000-4-2	Air ± 8kV and Contact ± 6kV	Perf. Criteria A
Radiated immunity	EN61000-4-3	20 V/m	Perf. Criteria A
Fast transient	EN61000-4-4	± 2kV	Perf. Criteria A
	43FED40-24□□□W	With an aluminum electrolytic capacitor (Nippon chemi-con KY series, 220µF/100V) and a TVS (SMDJ58A, 58V, 3000Watt peakpulse power) in parallel.	
	43FED40-48□□□W	With an aluminum electrolytic capacitor (Nippon chemi-con KY series, 220µF/100V) and a TVS (SMDJ120A, 120V, 3000Watt peakpulse power) in parallel	
	43FED40-110□□□W	With 2pcs aluminum electrolytic capacitor (Nippon chemi-con KXJ series, 150µF/200V in parallel) and 2pcs TVS (SMDJ90A, 90V, 3000Watt peak pulse power in series connection) in parallel	
Surge	EN61000-4-5	±2kV	Perf. Criteria A
	43FED40-24□□□W	With an aluminum electrolytic capacitor (Nippon chemi-con KY series, 220µF/100V) and a TVS (SMDJ58A, 58V, 3000Watt peakpulse power) in parallel.	
	43FED40-48□□□W	With an aluminum electrolytic capacitor (Nippon chemi-con KY series, 220µF/100V) and a TVS (SMDJ120A, 120V, 3000Watt peakpulse power) in parallel.	
	43FED40-110□□□W	With 2pcs aluminum electrolytic capacitor (Nippon chemi-con KXJ series, 150µF/200V in parallel) and 2pcs TVS (SMDJ90A, 90V, 3000Watt peak pulse power in series connection) in parallel	
Conducted immunity	EN61000-4-6	10 Vr.m.s	Perf. Criteria A
Power frequency magnetic field	EN61000-4-8	100A/m continuous; 1000A/m 1 second	Perf. Criteria A

CAUTION: This power module is not internally fused. An input line fuse must always be used.

Characteristic Curve

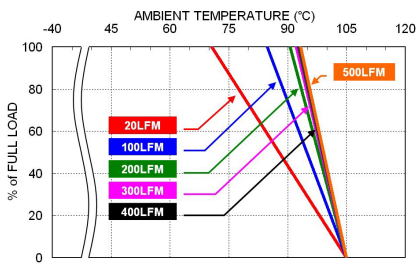

43FED40-48S05W Derating Curve

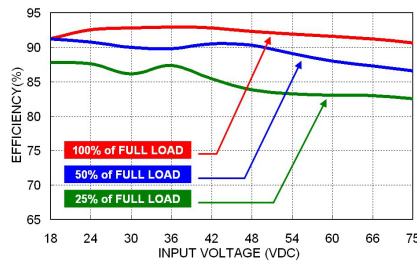

43FED40-48S05W Efficiency vs. Input Voltage

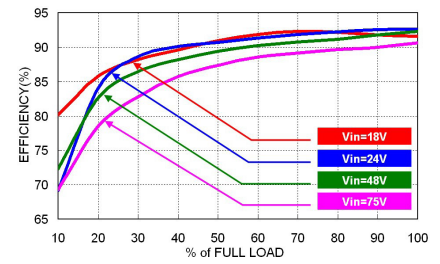

43FED40-48S05W Efficiency vs. Output Load

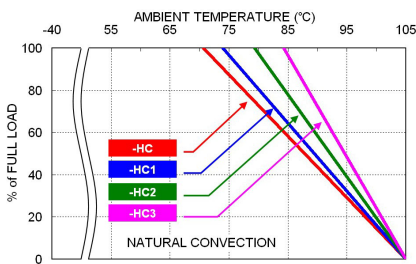

43FED40-48S05W Derating Curve with Heat-sink

Fuse Consideration

This power module is not internally fused. An input line fuse must always be used.

This encapsulated power module can be used in a wide variety of applications, ranging from simple stand-alone operation to an integrated part of sophisticated power architecture.

To maximum flexibility, internal fusing is not included; however, to achieve maximum safety and system protection, always use an input line fuse. The input line fuse suggest as below :

Model	Fuse Rating (A)	Fuse Type
43FED40-24□□□W	8	Fast-Acting
43FED40-48□□□W	4	Slow-Blow
43FED40-110□□□W	3.15	Slow-Blow

The table based on the information provided in this data sheet on inrush energy and maximum DC input current at low Vin.

Mechanical Drawing

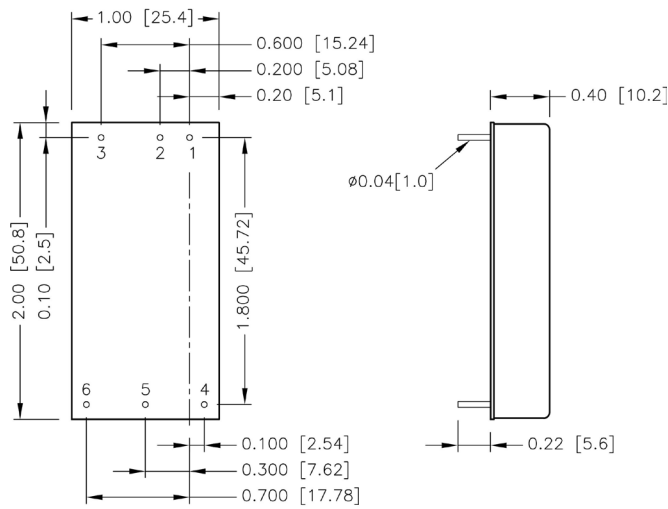

BOTTOM VIEW

1. All dimensions in Inch [mm]
2. Tolerance : X.XX±0.02 [X.X±0.5]
X.XXX±0.01 [X.XX±0.25]
3. Pin dimension tolerance ±0.004[0.10]

Terminal Connection

NO.	SINGLE	DUAL
1	+ Vin	+ Vin
2	- Vin	- Vin
3	Ctrl	Ctrl
4	+ Vout	+ Vout
5	- Vout	Common
6	Trim	- Vout

Recommended PAD Layout

Standard

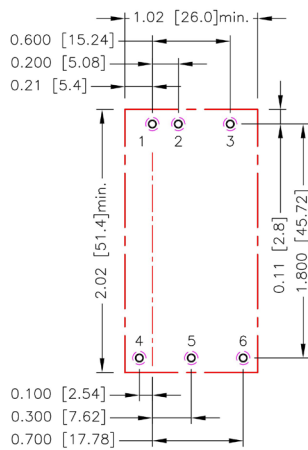

-HC

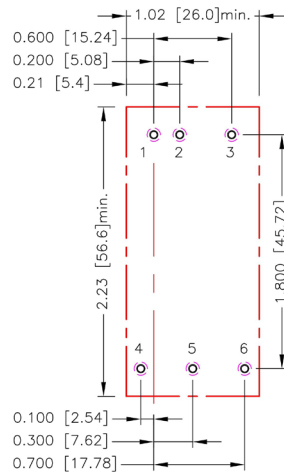

-HC1, -HC2, -HC3

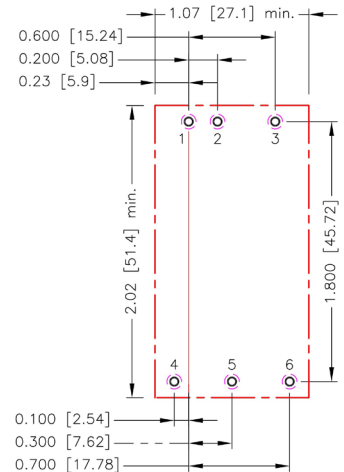

- All dimensions in inch[mm]
 Pad size(lead free recommended)
 Through hole 1.2.3.4.5.6: $\Phi 0.051[1.30]$
 Top view pad 1.2.3.4.5.6: $\Phi 0.064[1.63]$
 Bottom view pad 1.2.3.4.5.6: $\Phi 0.102[2.60]$

Thermal Considerations

The power module operates in a variety of thermal environments. However, sufficient cooling should be provided to help ensure reliable operation of the unit. Heat is removed by conduction, convection, and radiation to the surrounding Environment. Proper cooling can be verified by measuring the point as the figure below. The temperature at this location should not exceed "Maximum case temperature". When operating, adequate cooling must be provided to maintain the test point temperature at or below "Maximum case temperature". You can limit this Temperature to a lower value for extremely high reliability.

- Thermal test condition with vertical direction by natural convection (20LFM).

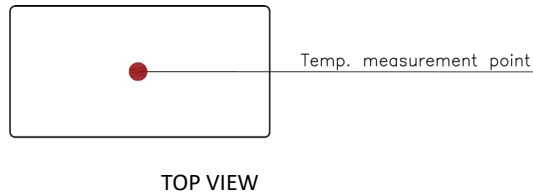

Heat-Sink Type Options

43FED40-□□□□W-HC
7G-0020C-F

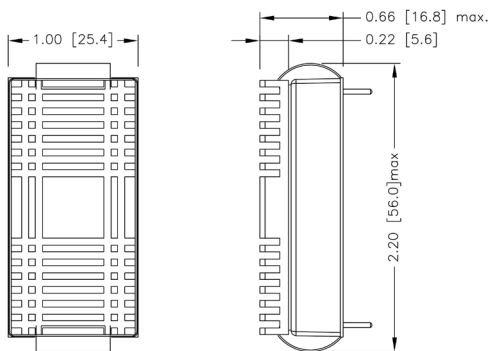

SIDE VIEW

43FED40-□□□□W-HC1
7GA0120P01-F

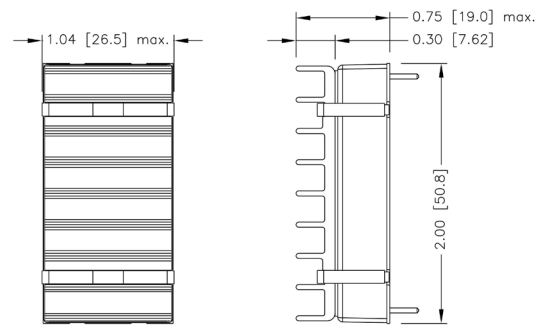

SIDE VIEW

43FED40-□□□□W-HC2
7GA0121P01-F

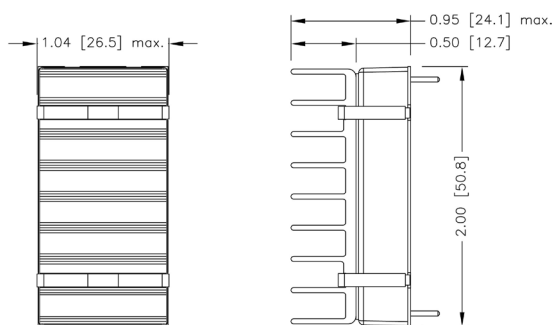

SIDE VIEW

43FED40-□□□□W-HC3
7GA0122P01-F

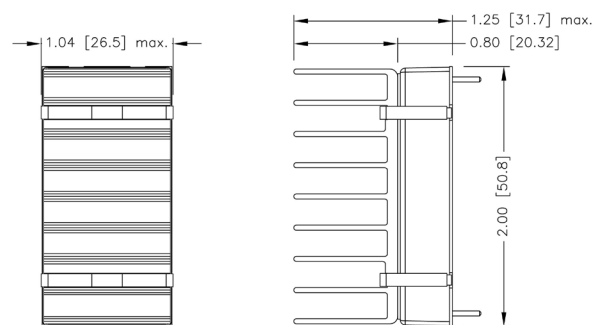

SIDE VIEW

1. All dimensions in inch [mm]
2. Tolerance :x.xx±0.02 [x.x±0.5]
x.xxx±0.010 [x.xx±0.25]

Output Voltage Adjustment

Output voltage is adjustable for 10% trim up or -20% trim down of nominal output voltage by connecting an external resistor between the Trim pin and either the +Sense or -Sense pins.

With an external resistor between the Trim and -Sense pin, the output voltage set point decreases.

With an external resistor between the Trim and +Sense pin, the output voltage set point increases.

Maximum output deviation is +10% inclusive of remote sense.

The external TRIM resistor needs to be at least 1/8W of rated power.

Trim Up
EXTERNAL OUTPUT TRIMMING

Output can be externally trimmed by using the method shown below.

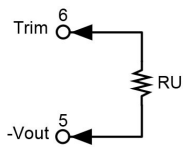
□□S3P3W

ΔV (%)	1	2	3	4	5	6	7	8	9	10
Vout (V)	3.333	3.366	3.399	3.432	3.465	3.498	3.531	3.564	3.597	3.630
RU (k Ω)	57.93	26.165	15.577	10.283	7.106	4.988	3.476	2.341	1.459	0.753

□□S05W

ΔV (%)	1	2	3	4	5	6	7	8	9	10
Vout (V)	5.050	5.100	5.150	5.200	5.250	5.300	5.350	5.400	5.450	5.500
RU (k Ω)	36.57	16.58	9.917	6.585	4.586	3.253	2.302	1.588	1.032	0.588

□□S12W

ΔV (%)	1	2	3	4	5	6	7	8	9	10
Vout (V)	12.120	12.240	12.360	12.480	12.600	12.720	12.840	12.960	13.080	13.200
RU (k Ω)	367.91	165.95	98.636	64.977	44.782	31.318	21.701	14.488	8.879	4.391

□□S15W

ΔV (%)	1	2	3	4	5	6	7	8	9	10
Vout (V)	15.150	15.300	15.450	15.600	15.750	15.900	16.050	16.200	16.350	16.500
RU (k Ω)	419.81	199.91	126.60	89.95	67.96	53.30	42.83	34.98	28.87	23.98

ΔV (%)	11	12	13	14	15	16	17	18	19	20
Vout (V)	16.650	16.800	16.950	17.100	17.250	17.400	17.550	17.700	17.850	18.000
RU (k Ω)	19.98	16.65	13.83	11.42	9.32	7.49	5.87	4.43	3.15	1.99

□□S24W

ΔV (%)	1	2	3	4	5	6	7	8	9	10
Vout (V)	24.240	24.480	24.720	24.960	25.200	25.440	25.680	25.920	26.160	26.400
RU (k Ω)	1275.2	606.60	383.73	272.30	205.44	160.87	129.03	105.15	86.58	71.72

ΔV (%)	11	12	13	14	15	16	17	18	19	20
Vout (V)	26.640	26.880	27.120	27.360	27.600	27.840	28.080	28.320	28.560	28.800
RU (k Ω)	59.56	49.43	40.86	33.51	27.15	21.57	16.66	12.29	8.38	4.86

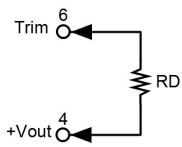
Trim Down

□□S3P3W										
ΔV (%)	1	2	3	4	5	6	7	8	9	10
Vout (V)	3.267	3.234	3.201	3.168	3.135	3.102	3.069	3.036	3.003	2.970
RU (k Ω)	69.47	31.235	18.49	12.117	8.294	5.745	3.924	2.559	1.497	0.647
□□S05W										
ΔV (%)	1	2	3	4	5	6	7	8	9	10
Vout (V)	4.950	4.900	4.850	4.800	4.750	4.700	4.650	4.600	4.550	4.500
RU (k Ω)	45.533	20.612	12.306	8.152	5.66	3.999	2.812	1.922	1.23	0.676
□□S12W										
ΔV (%)	1	2	3	4	5	6	7	8	9	10
Vout (V)	11.880	11.760	11.640	11.520	11.400	11.280	11.160	11.040	10.920	10.800
RU (k Ω)	460.99	207.95	123.6	81.423	56.118	39.249	27.199	18.162	11.132	5.509
□□S15W										
ΔV (%)	1	2	3	4	5	6	7	8	9	10
Vout (V)	14.850	14.700	14.550	14.400	14.250	14.100	13.950	13.800	13.650	13.500
RU (k Ω)	284.89	128.68	76.61	50.58	34.96	24.55	17.11	11.53	7.19	3.72
□□S24W										
ΔV (%)	1	2	3	4	5	6	7	8	9	10
Vout (V)	23.760	23.520	23.280	23.040	22.800	22.560	22.320	22.080	21.840	21.600
RU (k Ω)	838.15	376.78	222.98	146.09	99.95	69.19	47.22	30.74	17.93	7.68